

3378-2NM2-V104

BOOSTER PUMP

Key Features:

- All component materials meet stringent global approval standards (including NSF, FDA, and EC 1935/2004)
- Quiet, maintenance-free operation
- New design improves priming and diaphragm protection
- Enhanced sealing for leak resistance
- Compact design

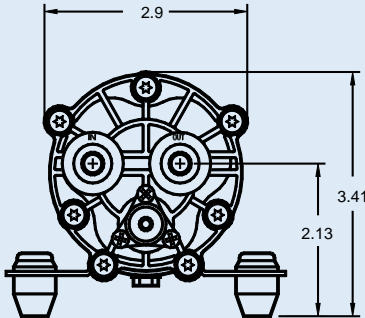

Technical Specifications:

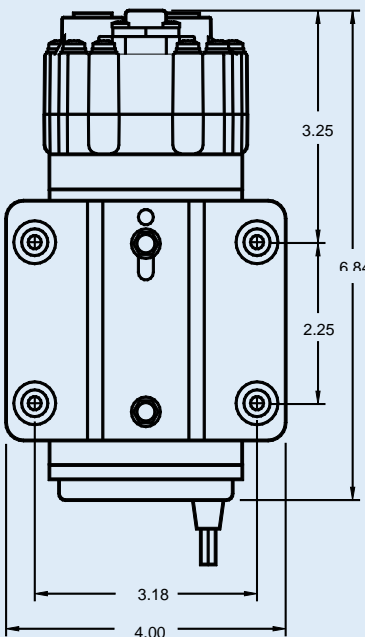

WEIGHT: 3.9 pounds

Pump design:	3 chamber diaphragm pump, self-priming, dry run tolerant
Typical applications:	Residential/light commercial feedwater boost for up to 200 GPD reverse osmosis and other filtration technologies as well as carbonation
Materials:	
Housing:	Nylon
Valves:	EPDM
Diaphragm:	Santoprene
Fasteners:	Stainless steel, zinc plated carbon steel
Liquid temperature:	170°F (77°C) maximum
Ports:	5/16" John Guest "Push-fit" (other options available)
Switch:	None
Bypass:	Pressure relief valve factory set to 150 PSI
Motor:	
Type:	Permanent magnet, totally enclosed, non-ventilated
Voltage:	24 VDC (other options available)
Leads:	18 AWG
Temp limits:	For user safety, optimal performance, and maximum motor life, this motor is equipped with a thermal protector that limits motor shell temperature to approximately 150°F (66°C)
Duty cycle:	See heat rise graph
Mounting plate:	Powder coated steel mounting plate (other options available)

3300 Series

Pump Model: 3378-2NM2-V104

All performance testing is conducted in a controlled environment with 70°F (21°C) ambient and water temperature, and 30 PSI inlet pressure. Voltage is fixed at 24 VDC. Both performance and heat rise data will vary with changes to environmental and operating conditions. Additional inlet pressure increase will result in similar increase in discharge pressure. Maximum inlet pressure rating is 80 PSI (5.4 Bar).

Shaded areas within the charts below denote performance points at which the pump can run continuously, without thermal breaker interruption. Within the unshaded areas, the pump will require periodic shutdown for motor cooling.

PERFORMANCE DATA		
DISCHARGE PRESSURE	30 PSI (2 BAR) INLET PRESSURE	
PSI (BAR)	FLOW: GPM (LPM)	CURRENT: AMPS
130 (10)	0.0	4.5
120 (8)	0.8 (3.0)	3.8
90 (6)	0.9 (3.4)	3.1
60 (4)	1.0 (3.8)	2.3
30 (2)	1.2 (4.5)	1.5

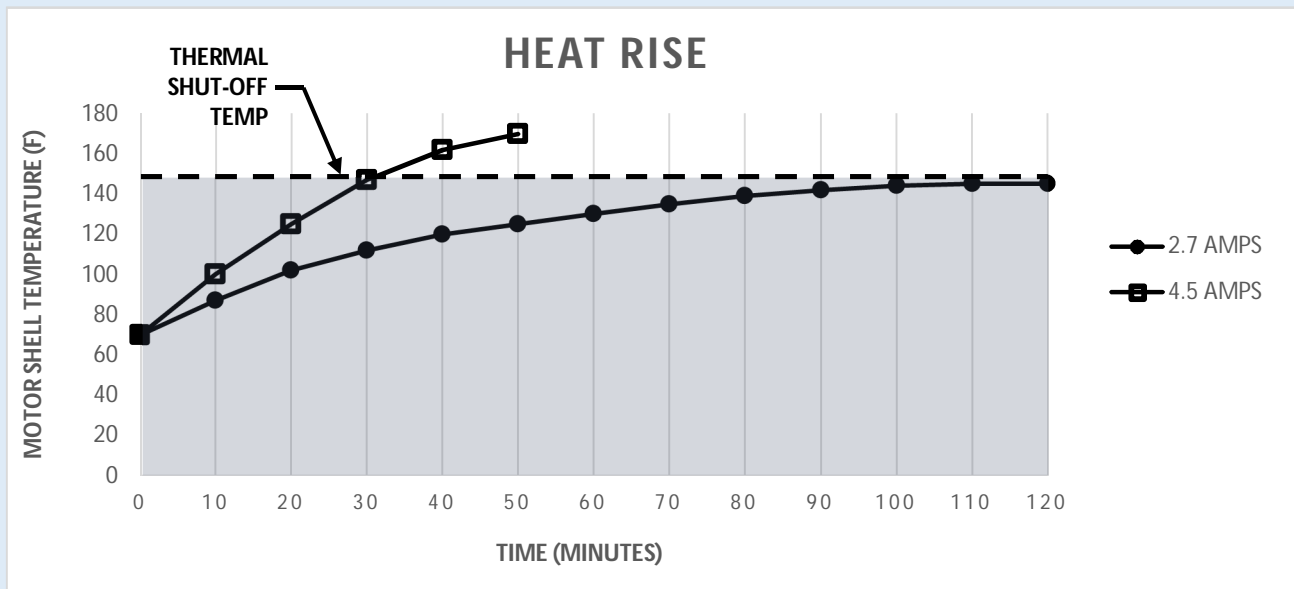

The lower curve of the Heat Rise graph plots the highest current where this pump model can run without a cooling requirement. The upper curve represents the highest current draw of this pump model, under which the thermal breaker would open after approximately thirty (30) minutes and the motor would require approximately twenty-five (25) minutes of cooling before it restarts. Power cycling should be limited to six (6) times per minute.

ALL PERFORMANCE AND HEAT RISE FIGURES ARE APPROXIMATE. ACTUAL VALUES WILL VARY ACCORDING TO AMBIENT AND OPERATING CONDITIONS.